

Wikipedia / Wikimedia: Watermarks and Filigranology

Frieder Schmidt (Germany)

7th International Conference on Watermarks in
Digital Collections

Verona, Italy, September 6-8, 2023

Free encyclopedia & collaborative writing

Wikipedia has been online as a non-profit project since January 15, 2001 and provides lexical knowledge as a donation funded free encyclopedia, which is developed according to the principle of collaborative writing.

Currently there are 318 active language versions with over 60 million articles. It has become a mass medium in terms of audience demand and distribution and has brought about the end of the great printed general encyclopedias.

Wikipedia is ranked 5th in the “Most Visited Websites by Traffic in the world for all categories, July 2023”.

Top 100 most visited websites globally (July 2023)

	Website	Monthly Traffic
1	google.com	106,500,000,000
2	youtube.com	94,500,000,000
3	facebook.com	12,100,000,000
4	twitter.com	8,400,000,000
5	wikipedia.org	7,600,000,000
6	instagram.com	5,900,000,000

<https://explodingtopics.com/blog/most-visited-websites>

Wikimedia Commons

- Wikipedia's main sister project is Wikimedia Commons, which is a collection of millions of free-to-use media files that anyone can contribute to.
- The main difference between these two is that the individual language versions of Wikipedia have a strong life of their own, while the Wikimedia Commons media objects are available for the various projects of the Wikimedia Foundation.
- *“Wikimedia Commons is a media file repository making available public domain and freely licensed educational media content (images, sound and video clips) to everyone, in their own language.”*
- *“The content can be used by anyone, anywhere, for any purpose.”*

Paper and its history in Wikipedia

- Wikipedia and Wikimedia Commons contain numerous articles and media objects on the subject of paper: raw materials, techniques, types, uses, manufacturers, users, collectors and collections, etc.
- At the 36th Congress of the International Association of Paper Historians (IPH), held in Krems (Austria) in August 2022, I gave the following report: *Paper and its History in the German-Language Wikipedia - An Inventory*
- When the lecture was published in 2023, I was able to add the table of contents to a list of links from Wikipedia:
- I have compiled a list of corresponding links for about 3 dozen languages. This has been updated several times and is publicly available on the IPH website:
https://www.paperhistory.org/Wikipedia/wiki_links_paper.pdf
- Many thanks to Emanuel Wenger for continuous support!

Multilingualism of Wikipedia

This list of paper links respects 34 languages

bg. = Bulgarian	id. = Indonesian	ru. = Russian
ca. = Catalan	it. = Italian	sh. = Serbo-Croatian
cs. = Czech	ja. = Japanese	sk. = Slovak
da. = Danish	ko. = Korean	sl. = Slovenian
de. = German	lt. = Lithuanian	sr. = Serbian
el. = Greek	lv. = Latvian	sv. = Swedish
en. = English	mk. = Macedonian	tr. = Turkish
es. = Spanish	nl. = Dutch	uk. = Ukrainian
et. = Estonian	no. = Norwegian	vi. = Vietnamese
fi. = Finnish	pl. = Polish	zh. = Chinese
fr. = French	pt. = Portuguese	
hu. = Hungarian	ro. = Romanian	

Consequences of multilingualism

- The context of the individual articles is shaped in the individual language versions by the corresponding needs and the cultural and historical circumstances.
- Geographical contexts are treated in different ways (places, rivers, etc.)
- There are big differences in the particular people who are treated or not mentioned

New focus: world of watermarks

The question now is how well the world of watermarks is represented. It is about

- the production technique (handmade and machinemade paper),
- the variety of watermark motifs,
- the watermarks in different paper grades
- the documentation methods,
- the collections and databases,
- the scholars etc.

The lemma „Watermark“ in different language versions

- <https://de.wikipedia.org/wiki/Wasserzeichen>
- <https://en.wikipedia.org/wiki/Watermark>
- <https://es.wikipedia.org/wiki/Filigrana> (papel)
- <https://fi.wikipedia.org/wiki/Vesileima>
- <https://fr.wikipedia.org/wiki/Filigrane>
- <https://it.wikipedia.org/wiki/Filigrana> (carta)
- <https://nl.wikipedia.org/wiki/Watermerk>
- <https://no.wikipedia.org/wiki/Vannmerke>
- https://pl.wikipedia.org/wiki/Znak_wodny
- https://pt.wikipedia.org/wiki/Marca_d'água

Elements/aspects in the different language variants of “Watermark”

	de.	en.	es.	fi.	fr.	it.	nl.	no.	pl.	pt.
paper + digital	X X	X X	X X		X	X	X X	X X		
handmade	X		X	X	X	X	X	X	X	X
dandy roll	X	X	X	X	X		X			
cylinder mould		X		X						
paper money	X	X	X	X			X			X
stamps		X	X		X	X	X	X		
fakes									X	X
db links	X	X	X		X		X		X	

Category:Watermarks in Wikimedia Commons

Subcategories

This category has the following 39 subcategories, out of 39 total.

A

- ▶ A in watermarks (10 F)
- ▶ Anchors in watermarks (4 F)
- ▶ Annulets in watermarks (2 F)

B

- ▶ B in watermarks (12 F)
- ▶ Barbels in watermarks (4 F)

C

- ▶ C in watermarks (6 F)
- ▶ Chiaroscuro watermarks (7 F)
- ▶ Crowns in watermarks (86 F)

D

- ▶ D in watermarks (6 F)

E

- ▶ E in watermarks (2 F)
- ▶ Eagles in watermarks (2 F)
- ▶ Euro banknote watermarks (8 F)

F

- ▶ F in watermarks (1 F)
- ▶ Fleur-de-lis in watermarks (42 F)
- ▶ Filigrane en France (360 F)

G

- ▶ G in watermarks (9 F)
- ▶ Grapevines in watermarks (29 F)

H

- ▶ H in watermarks (3 F)
- ▶ Hands in watermarks (14 F)
- ▶ Hearts in watermarks (31 F)

I

- ▶ I in watermarks (3 F)
- ▶ Images with digital timestamps (3 F)
- ▶ Images with watermarks (45 C, 600765 F)

J

- ▶ Jester in watermarks (1 F)
- ▶ Jugs in watermarks (7 F)

K

- ▶ K in watermarks (1 F)

L

- ▶ L in watermarks (7 F)

M

- ▶ M in watermarks (11 F)

- ▶ Marmots in watermarks (2 F)

N

- ▶ N in watermarks (6 F)

P

- ▶ P in watermarks (7 F)

Q

- ▶ Quatre-feuilles in watermarks (78 F)

R

- ▶ R in watermarks (7 F)
- ▶ Watermarks in the Robert C. Williams Paper Museum (6 F)

S

- ▶ S in watermarks (5 F)
- ▶ Watermarks on stamps (2 C, 29 F)
- ▶ Stars in watermarks (13 F)

















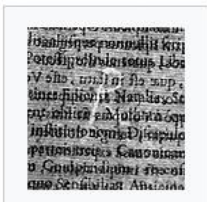

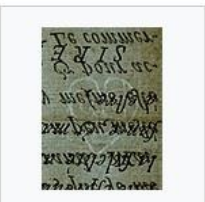

V

- ▶ Videos with watermarks (1 F)

W

- ▶ Watermarks on music paper (3 F)

Media in category "Filigrane en France"

						
Airs de cour Moulinié filigrane 83607.jpg 1,100 × 759; 452 KB	Almanach luniare filigrane 10111.jpg 814 × 539; 433 KB	Amico criticae 82509.jpg 1,452 × 1,331; 1.5 MB	AnDré Cursin 69315.jpg 495 × 704; 341 KB	AnDré Cursin 69316.jpg 1,128 × 972; 978 KB	AnDré Cursin 69317.jpg 1,721 × 2,063; 3.22 MB	AnDré Cursin 69318.jpg 530 × 800; 432 KB
						
Animadversiones 1202215 filigrane.jpg 556 × 577; 290 KB	Au roy 82501.jpg 1,358 × 1,980; 2.19 MB	Au roy 82502.jpg 814 × 1,094; 751 KB	Au roy 82503.jpg 3,542 × 2,640; 7.4 MB	Basile de Cappadoce Oraciones 61665.jpg 671 × 677; 269 KB	Bibliotheca telleriana 1202196 filigrane.jpg 1,416 × 744; 620 KB	Bibliotheca telleriana 1202201 filigrane.jpg 1,422 × 690; 726 KB
						
Boulard Cahr 08621.jpg 1,353 × 517; 277 KB	Boulard Couronne 08620.jpg 1,199 × 1,281; 449 KB	Boulard couronne 08621.jpg 655 × 643; 122 KB	Boulard couronne B 08621.jpg 1,134 × 600; 203 KB	Boulard cygne 08621.jpg 1,166 × 885; 254 KB	Boulard filigrane 08621.jpg 920 × 365; 117 KB	Boulard G Cahr 08621.jpg 1,075 × 289; 140 KB



Disappointing results

Category: Eagles in watermarks

From Wikimedia Commons, the free media repository

Media in category "Eagles in watermarks"

The following 2 files are in this category, out of 2 total.

	
<p>Filigrana del papel libro de concejo 1698-1772-Navamorales.JPG 749 × 1,833; 467 KB</p>	<p>Filigrane 04794.jpg 678 × 807; 525 KB</p>



Categories: [Watermarks](#) | [Eagles in art](#)

Category: Watermarks on music paper

From Wikimedia Commons, the free media repository

Media in category "Watermarks on music paper"

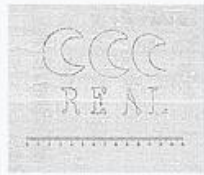
The following 3 files are in this category, out of 3 total.

		
<p>MARCMUS - WM0009.jpg 2,688 × 2,251; 1.46 MB</p>	<p>WM0009 02 countermark.jpg 2,013 × 2,650; 1.28 MB</p>	<p>WM0009 03 sheet.jpg 9,267 × 6,971; 2.96 MB</p>

Category: [Watermarks](#)

This page was last edited on 23 May 2023, at 11:13.

Coat of arms of Augsburg in watermarks

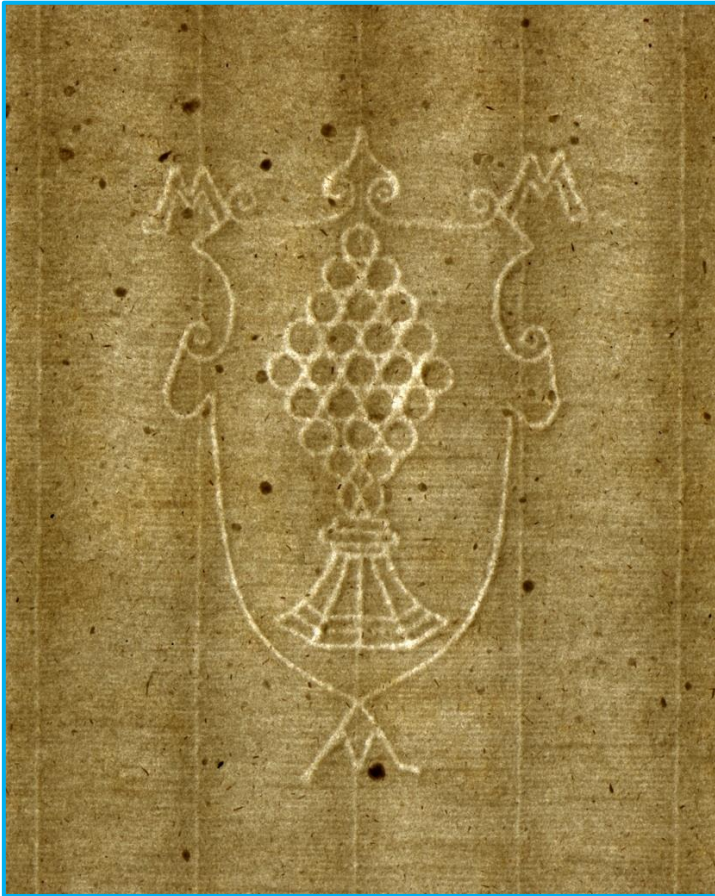

Mathaeus Mair
Augsburg,
around 1625,
Obere Papier-
mühle an der
Sinkel

Wasserzeichen-
Kartei Piccard
Band XIV
Frucht
Stuttgart 1983

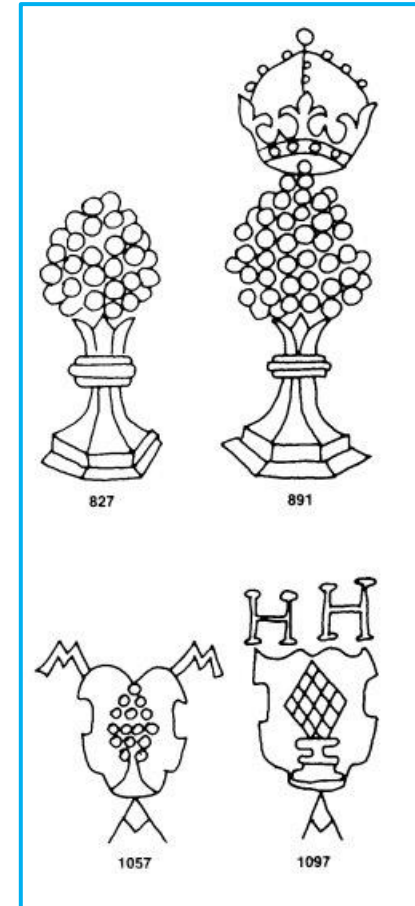

Category:Coats of arms of Augsburg

Subcategories























This category has only the following subcategory.

C

- Coat of arms of Augsburg on coins (20 F)

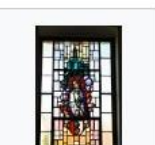
Media in category "Coats of arms of Augsburg"

The following 40 files are in this category, out of 40 total.

							<p>coat of arms of Augsburg [Collapse]</p>  <p>Upload media ^ℹ</p> <p>Instance of local coat of arms (Augsburg)</p> <p>Location Germany</p> <p>Applies to jurisdiction Augsburg</p> <p>Authority file ^ℹ [Collapse]</p> <p>Q108062657</p> <p>Reasonator ^ℹ · Scholia ^ℹ · PetScan ^ℹ · statistics ^ℹ · WikiMap ^ℹ · Locator tool ^ℹ · KML file ^ℹ · Search depicted</p>
<p>Kürschnerwappen zu Augsburg.jpg 1,819 × 1,811; 181 KB</p>	<p>Augsburg 8.JPG 1,920 × 2,560; 3.72 MB</p>	<p>Augsburg Kanaldeckel 658.jpg 4,507 × 3,005; 13.1 MB</p>	<p>Augsburg Kanaldeckel 659.jpg 3,919 × 2,612; 9.07 MB</p>	<p>Augsburg Stadtansicht von Osten Rogel Hans.jpeg 2,048 × 1,539; 987 KB</p>	<p>Augsburg Wappen Rathaus München.jpg 1,524 × 1,553; 315 KB</p>	<p>Augsburg wappen.png 218 × 250; 7 KB</p>	
							
<p>Augsburg, Staatsbibliothek, Supraporte des Unteren Zimelienensaals, 3.jpeg 3,520 × 5,152; 7.95 MB</p>	<p>Augsburg-Kanaldeckel-02-mit Wappen-gje.jpg 3,606 × 3,337; 3.37 MB</p>	<p>Augsburger Posthaus.jpg 926 × 762; 181 KB</p>	<p>Aumühle Bturm P5200105.JPG 2,288 × 1,712; 1.97 MB</p>	<p>Aumühle Bturm P5200106a.jpg 2,284 × 1,404; 2.25 MB</p>	<p>Bibliotheksgebäude Fassadendetails - 2022-06-03 - 644c.jpg 3,392 × 2,544; 1.2 MB</p>	<p>Braun Augsburg UBHD.jpg 2,076 × 1,490; 2.23 MB</p>	
							
<p>CoA Augsburg, Bavaria.svg 600 × 660; 51 KB</p>	<p>DBP 1985 1234 Augsburg.jpg 1,070 × 670; 374 KB</p>	<p>De Merian Sueviae 022.jpg 3,000 × 2,316; 1.59 MB</p>	<p>DEU Augsburg COA.svg 455 × 521; 13 KB</p>	<p>Dillingen Akademie Fenster 961.JPG 2,592 × 3,888; 7.1 MB</p>	<p>Eingangstür zur Ausstellung „Tulpenschau im" data-bbox="550 730 630 830"/> „Tulpenschau im</p>	<p>Exlibris Elementa 1482.jpg 3,104 × 6,416; 3.27 MB</p>	<p>Grand Coat of Arms of Augsburg.svg 766 × 801; 1.82 MB</p>

Category:Coat of arms of Augsburg on coins

Category:Coat of arms of Augsburg on coins Good pictures Help

Wikimedia Commons auf Deutsch





















From Wikimedia Commons, the free media repository

Language select:

Deutsch: Augsburger Wappen (Zirbelnuss, Pyr) auf Münzen
English: Coat of arms of Augsburg on coins
Español: Blasón de Augsburg en monedas
Français: Blason d'Augsbourg en monnaies
Italiano: Stemma di Augusta in monete

Media in category "Coat of arms of Augsburg on coins"

The following 20 files are in this category, out of 20 total.

									
Augsburg Guldentaler 1560.2 (obv).jpg 1.493 × 1.472; 1.68 MB	Augsburg Goldgulden 1566.1 (obv).jpg 895 × 898; 709 KB	Augsburg Taler 1623.2 (obv).jpg 1.584 × 1.581; 1.77 MB	Augsburg 10 Dukaten 1625.1 (obv).jpg 1.822 × 1.830; 2.6 MB	Augsburg Taler 1625.8 (obv).jpg 1.648 × 1.618; 2.05 MB	Augsburg 1-6 Taler 1626.20 (obv).jpg 1.006 × 971; 828 KB	Augsburg 2 Taler 1626.6 (obv).jpg 1.975 × 1.945; 2.76 MB	Augsburg Vierfacher St.- Afra-Dukat 1630.1 (obv).jpg 1.170 × 1.164; 1.19 MB	Augsburg Gustav- Adolph-Dukat 1635.1 (rev).jpg 816 × 790; 629 KB	Augsburg 3 Dukaten 1672.1 (obv).jpg 996 × 987; 931 KB
									
Augsburg Taler 1689.2 (obv).jpg 1.618 × 1.608; 1.95 MB	Augsburg Taler 1694.4 (obv).jpg 1.671 × 1.671; 2.15 MB	Augsburg 2 Pfennig 1725.5 (obv).jpg 965 × 919; 586 KB	Augsburg Dukat 1737.1 (obv).jpg 867 × 859; 701 KB	Augsburg Dukat 1738.2 (obv).jpg 788 × 764; 419 KB	Augsburg 12 Dukaten 1740.(Vs).jpg 1.720 × 1.710; 2.18 MB	Augsburg Taler 1740.3 (obv).jpg 1.624 × 1.604; 1.99 MB	Augsburg 12 Dukaten 1745.1 (obv).jpg 1.662 × 1.608; 1.97 MB	Augsburg Halber Konventionstaler 1763.5 (obv).jpg 1.299 × 1.305; 999 KB	Augsburg - Maximilianmuseum - Mattes (20).JPG 1.927 × 1.947; 1.98 MB

Categories: Coats of arms of Augsburg | Coats of arms on coins | Augsburg on coins

Charles M. Briquet, Les Filigranes Armoiries, Pomme de Pin

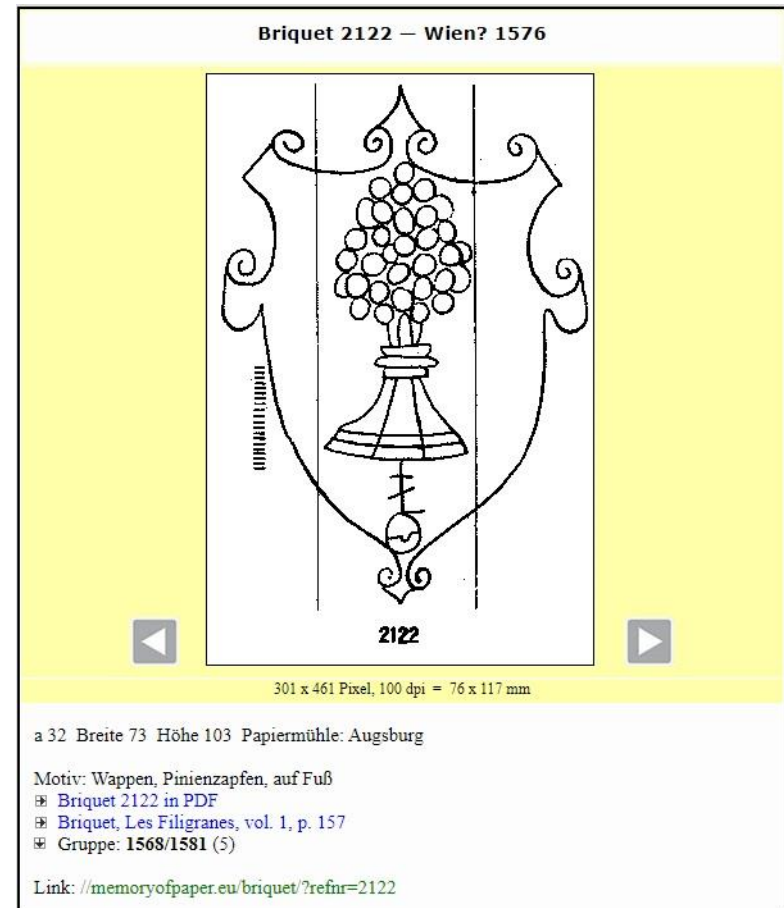
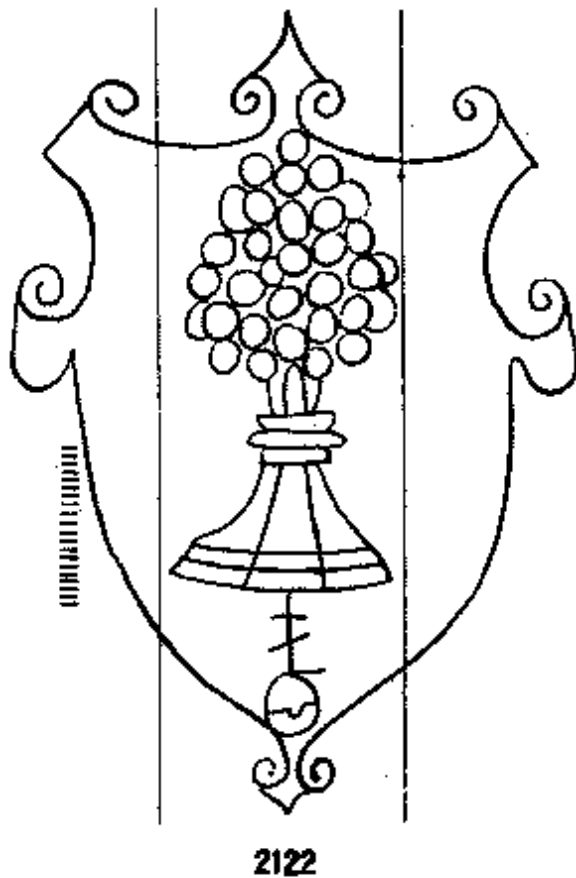

How to enrich Wikimedia Commons? An example

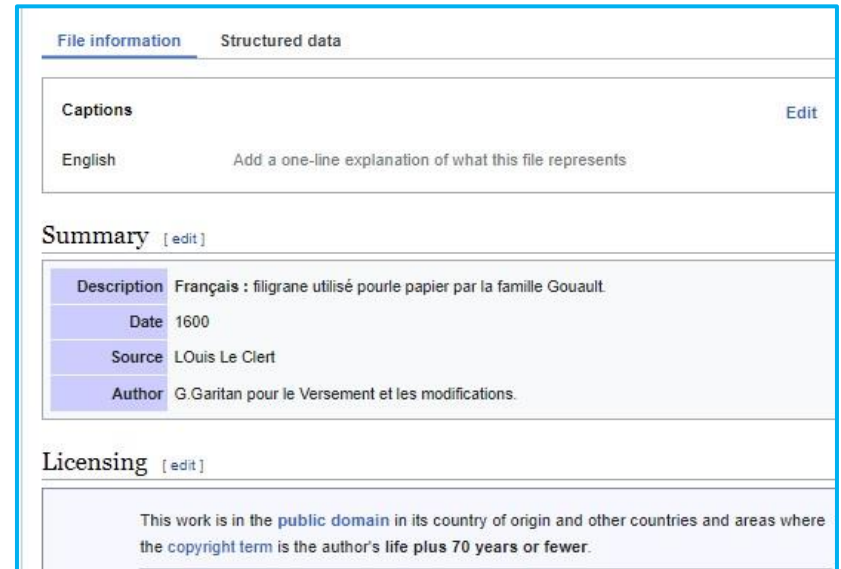
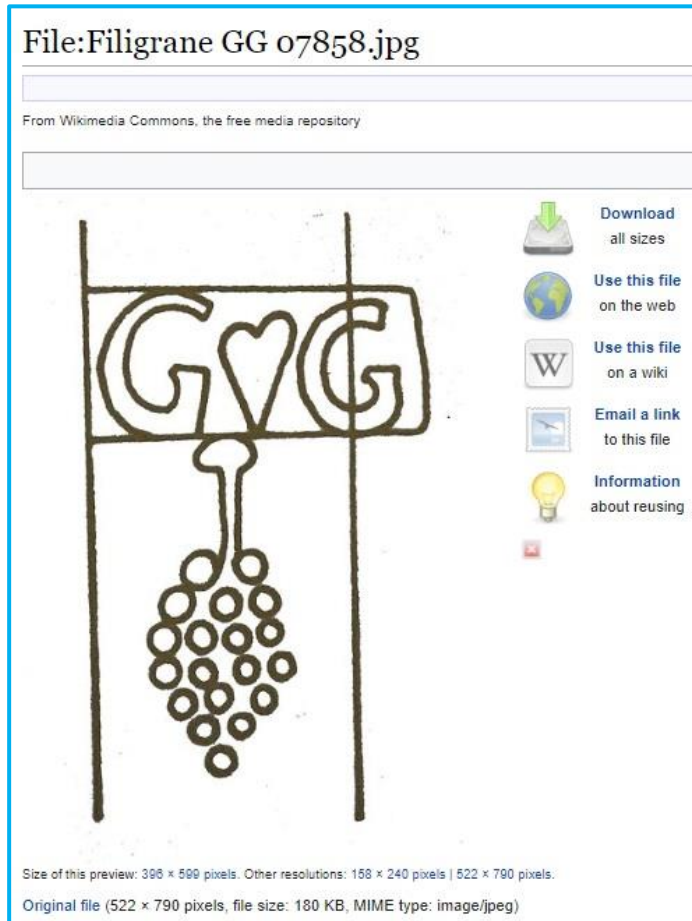

Categories:

- Filigrane en France
- Hearts in watermarks
- G in watermarks
- Grapevines in watermarks

Sources

Who was Louis Le Clert?

- He is mentioned in https://fr.wikipedia.org/wiki/Moulin_%C3%A0_papier
- « En se basant sur les archives de Troyes, l'historien Louis Le Clert affirme que le premier moulin à papier, le moulin de la Moline est construit en 1348 au bord du canal de dérivation de la Seine, à quelques kilomètres au sud de la ville de Troyes, alors capitale de la Champagne. »
- https://data.bnf.fr/fr/11911552/louis_le_clert/
Louis Le Clert (1835-1932) Conservateur du musée archéologique de Troyes, historien

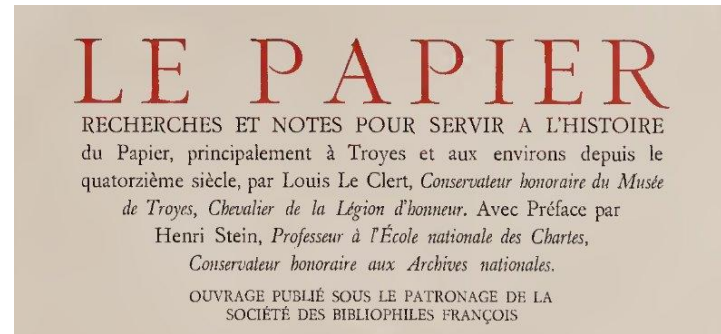

Titre(s) : Le papier, recherches et notes pour servir à l'histoire du papier, principalement à Troyes et aux environs depuis le XIV^e siècle [Texte imprimé] / par Louis Le Clert,... ; avec préface par Henri Stein,...

Publication : Paris : A l'enseigne du Pégase, 1926

Impression : 71-Mâcon : impr. de Protat frères

Description matérielle : 2 vol. (266 p-XXIII pl., paginé 269-530- pl. XXIV- LXXVIII) : fig., pl. en noir et en coul., fac-sim., dépliant ; in-fol.

Comprend : Tome 1, Généralités. Les moulins à papier de la région troyenne ; Tome 2, Les papetiers de Troyes et de la région

Note(s) : Index, tables

Category:Le Papier par Louis le Clert

From Wikimedia Commons, the free media repository

Media in category "Le Papier par Louis le Clert"

The following 15 files are in this category, out of 15 total.



Categories: Louis Le Clert | 1926 books from France

The scholars in the field of filigranology

https://de.wikipedia.org/wiki/Liste_von_Wasserzeichenforschern

Liste von Wasserzeichenforschern

Dies ist eine **Liste von Wasserzeichenforschern**. Diese Personen erforschen historische Wasserzeichen. Viele von diesen Personen haben Wasserzeichen gesammelt und in gedruckten Katalogen veröffentlicht. Eine umfangreiche Liste dieser Wasserzeichenkataloge findet sich auf der Website der [Internationalen Arbeitsgemeinschaft der Papierhistoriker \(IPH\)](#).^[1] Wasserzeichenforscher heutzutage speichern vorwiegend ihre Wasserzeichen in Datenbanken und machen diese online zugänglich.^[2]

Personen [Bearbeiten]

Inhaltsverzeichnis [A](#) [B](#) [C](#) [D](#) [E](#) [F](#) [G](#) [H](#) [I](#) [J](#) [K](#) [L](#) [M](#) [N](#) [O](#) [P](#) [Q](#) [R](#) [S](#) [T](#) [U](#) [V](#) [W](#) [X](#) [Y](#) [Z](#)

A [Bearbeiten]

- Viktor Akantisz (1864–1943), Ungarn^[3]
- Julija V. Andrjušajtite, Russland^[4]

B [Bearbeiten]

- Karol Józef Badecki (1886–1953), Polen
- Nana Badenber (* 1964), Deutschland, Schweiz^[5]

Filigranologists in Wikipedia

- https://pl.wikipedia.org/wiki/Włodzimierz_Budka
- https://de.wikipedia.org/wiki/Theo_Gerardy
- https://de.wikipedia.org/wiki/Alois_Haidinger
- https://fr.wikipedia.org/wiki/Jean_Irigoin
- https://de.wikipedia.org/wiki/Emile_Joseph_Labarre
- https://en.wikipedia.org/wiki/Nikolay_Likhachyov
- https://uk.wikipedia.org/wiki/Мацюк_Орест_Ярославович
- https://cs.wikipedia.org/wiki/Joseph_Meder
- https://sh.wikipedia.org/wiki/Vladimir_Mošin
- https://de.wikipedia.org/wiki/Gerhard_Piccard
- https://pl.wikipedia.org/wiki/Jadwiga_Siniarska-Czaplicka
- https://en.wikipedia.org/wiki/Allan_H._Stevenson
- https://de.wikipedia.org/wiki/Walter_F._Tschudin
- https://de.wikipedia.org/wiki/Karl_Theodor_Weiß
- https://fr.wikipedia.org/wiki/Martin_Wittek

Summary by a Wikipedia evangelist

- Wikipedia offers detailed information in many areas of knowledge, e.g. botany, geography, literature, history
- Wikipedia provides context and helps people understand connections
- In an open society, experts do a good job when they share their knowledge with many people
- Therefore, please write and revise articles in your languages
- ... and add a lot of watermark images to Wikimedia Commons!